



Dishwasher

DBI564PS

40 series

Noise level (max): 42 dB(A)

Number of place settings: 16 pcs

Number of racks: 3

Size: XL

Turbo Combi Drying™ ensures dry dishes with fan assisted evacuation of moisture in combination with Auto Door Opening

ADA Compliant: Yes

Installation: Built-in



AMERICANS WITH
DISABILITIES ACT



Most Efficient
2025
www.energystar.gov

Construction and performance

- 8 Steel™ - Vital parts of the dishwasher made in stainless steel: Yes
- No need to rinse the dishes thanks to Super Cleaning System™: Yes
- Automatic water-softener for better washing performance: No
- Number of spray arms: 3 pcs
- Number of spray zones: 9
- Cleaning systems: Adjustable power zones that can be set for cleaning Pots & Pans or Bottles & Vases. Can also be turned off., Stainless steel spray arms, Aqua Level™ Sensor, No need to rinse the dishes thanks to Super Cleaning System™, Cutlery Spray™ - Extra dishwashing power for the cutlery basket
- Exterior handle: Pro- series

Use and flexibility

- Number of place settings: 16 pcs
- Number of racks: 3
- Top tray: Easy height adjustment, Handle, Removable
- Upper rack type: Premium, fixed tines and foldable wine shelves
- Upper basket system: Switch wheels
- Upper basket: Standard knife stand, Fixed glass support, Fixed pin rows, Foldable wine shelves to right, Foldable wine shelves to left, Handle with plastic logotype, Small distance between the basket threads - makes loading easy and prevents small items to fall through
- Middle basket: Without middle basket
- Lower rack type: Premium - Basket wiring in steel, fixed pin rows and removable cutlery basket
- Lower rack: Small distance between the basket threads - makes loading easy and prevents small items to fall through., Handle with plastic logotype, Foldable/divisible rear pin row, Cutlery basket
- Automatic dosing system: No
- Interior light: No

Interaction and control

- Wifi: No
- Type of display: LCD display
- Status Light™ - Visual indication of dishwashing progress: Yes, spot on floor
- Remaining time indication: Yes
- Wash end indication: Displayed with sound and light
- Language settings: Chinese simplified, Chinese traditional, Swedish, Slovenian, Slovak, Russian, Portuguese, Polish, Norwegian, Dutch, Latvian, Lithuanian, Japanese, Italian, Croatian, French, Finnish, Estonian, Spanish, English, German, Danish, Czech

Functions, programs and modes

- Programs: Anti odour, Sanitize, Light wash, Self cleaning, Rinse and hold programme, Time program, Standard, Intensive program, Quick wash
- Delayed start: Possible to delay up to 24 hours
- Options and modes: Enable/disable automatic door opening, Super Rinse™
- Two extra rinses, Time set, Speed mode - The program time is shortened. More energy is used., Night mode - Lower noise level. The program time is extended., Heat Boost Mode

Design and integration

- From the front adjustable door spring: No
- From front adjustable rear foot: Yes
- Installation: Multi fit outlet hose, Integrated anti-siphon - Prevents spontaneous in- and outlet of water and simplifies elevated installation, Trim kit, Steam protection strip
- Sliding door: No
- Possible to install elevated: Yes
- Min. niche width: 24 "
- Min. niche height: 32 11/16 "
- Depth (incl. wall spacing): 21 7/8 "
- Max Height adjustment: 2 1/16 "
- Adjustable kick plate: No

Safety and maintenance

- Aqua Safe™: Anti Block™ - Self cleaning drain pump, Light and sound alarm, Maximum time for water intake, Extra durable PEX inlet hose, Stand-by water protection - Leakage detection when machine is off, Aqua Level™ Sensor - Ensures an optimized water level, Aqua Detect™ - Instant recognition of any leakage in the motor compartment, Detection of water leakage on the bottom plate, Waterproof bottom plate, Extra durable stainless steel container, Sealing points outside container
- Aqua Safe™ system: Yes
- Child safety: Kid Safe™ - Lockable controls
- Indication of low level of rinse-aid: Notification in display

Technical data

- Water connection: Hot or cold
- Adapter for water connection: No
- Max. temperature of inflow water: 140 °F
- Noise level (max): 42 dB(A)
- Reference programme: 1
- Duration of standard programme: 125 min
- Estimated yearly energy consumption: 220 kWh
- Energy consumption - normal program: 1 kWh
- Estimated annual water consumption: 647.5 gal
- Water consumption: 3 gal
- Power consumption in standby mode: 0.5 W
- Plug type: USA
- Connected load: 1300 W
- Voltage (V): 120 V
- Number of phases: 1
- Fuse: 15 A
- Frequency: 60 Hz
- Required inlet water pressure psi: 0,03-1
- Net weight: 90.4 lb

Dimensions

- Width: 23 15/16 "
- Height: 32 11/16 "
- Depth: 21 13/16 "
- Maximum product height: 34 13/16 "
- Length of electrical cord: 71 7/16 "
- Depth with door open: 46 7/8 "
- Length inlet hose: 64 3/16 "
- Length outlet hose: 90 9/16 "

Logistic information

- Packaging width: 25 3/16 "
- Packaging height: 35 1/16 "
- Packaging depth: 27 3/16 "
- Gross weight: 97 lb
- Product code: 742941
- EAN code: 3838782774393

Measurements: inches / millimetres

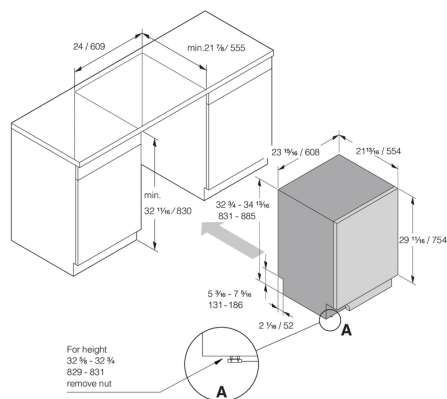

DW60 Built-in Dishwasher XL USA

